



SÜDMO DSV COMPLETE DOUBLE SEAT VALVES

DOUBLE SEAT VALVE SERIES DSV COMPLETE

Based on its many years of experience in valve construction, Súdmo offers a comprehensive, refined double-seat valve for implementation and automation of widely varying production processes in the food and beverage industry.

Why use Súdmo double seat valves?

As well as a wide range, the series is characterized by ease of handling and maintenance, and is therefore the ideal component for operating your processes with maximum efficiency and safety.



GENERAL REQUIREMENTS FOR HYGIENIC DOUBLE SEAT VALVES

- Reliable separation of two media (e.g. product and cleaning liquid)
 - > Two sealing elements work separately
 - > Leakage chamber open to atmosphere
 - Avoids pressure build-up
 - Visual leak detection
- All surfaces in contact with product can be cleaned

FUNCTION

The function of the double-seat valve is shown in the below tank farm application example.

Simultaneous, programmed filling, emptying and cleaning of four production lines without risk of mixing. Reliable separation of upper and lower valve housing allows one or more lines (purple and red lines) to be cleaned during production (yellow and green lines).

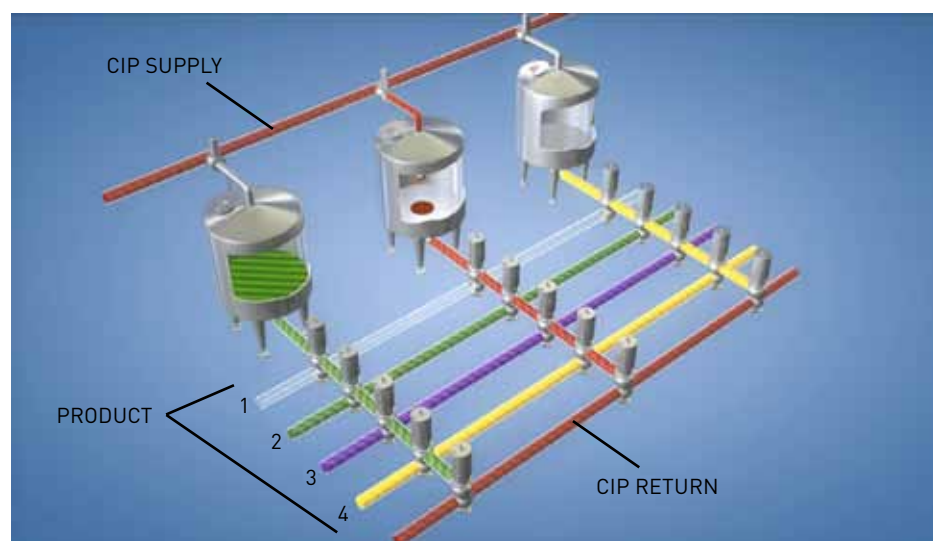



HIGH PROCESS RELIABILITY LOW OPERATING COSTS SUSTAINED VALVE INNOVATION

INNOVATIVE SEALING CONCEPT

In seat area

- Step seat with conical seal o-ring
- Radial seat with RSC seal (Radial Seal Complete)

In shaft area

- Sealing by form-fit profile seal

HIGH OPERATING PRESSURES

- Open, close and seal up to 10 bar*
- High pressure pulse resistance

* Depending on type and nominal width

SAFE CLEANING

- Cycle stroke with defined ring gap
- Leakage chamber flushing via external connection
- Sterile chamber for shaft flushing / sterilization
- Shaft flushing of lower valve disc

OPTIMIZED DRIVE & CONTROL CONCEPT

- Durable pneumatic seals
- Main spring with chambers
- All valve positions can be monitored IntelliTop 2.0 control unit

TOP QUALITY

- Body machined from solid bar stock
- High surface quality
- Reduced-friction surfaces on moving parts
- Design optimized for cleaning

SERVICE

- Simple, rapid maintenance
- No special tools needed
- Easy handling thanks to compact construction
- Low maintenance costs (Opex)

LICENCES & CERTIFICATES

- EHEDG
- 3A
- PMO
- ATEX
- CRN
- Official licences for use in milk heaters
- All seals comply with FDA standards
- Optional USP Class VI

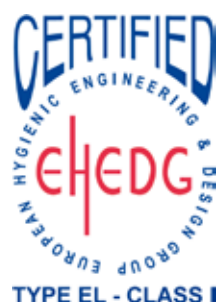

STRUCTURE OF DSV COMPLETE DOUBLE SEAT VALVES

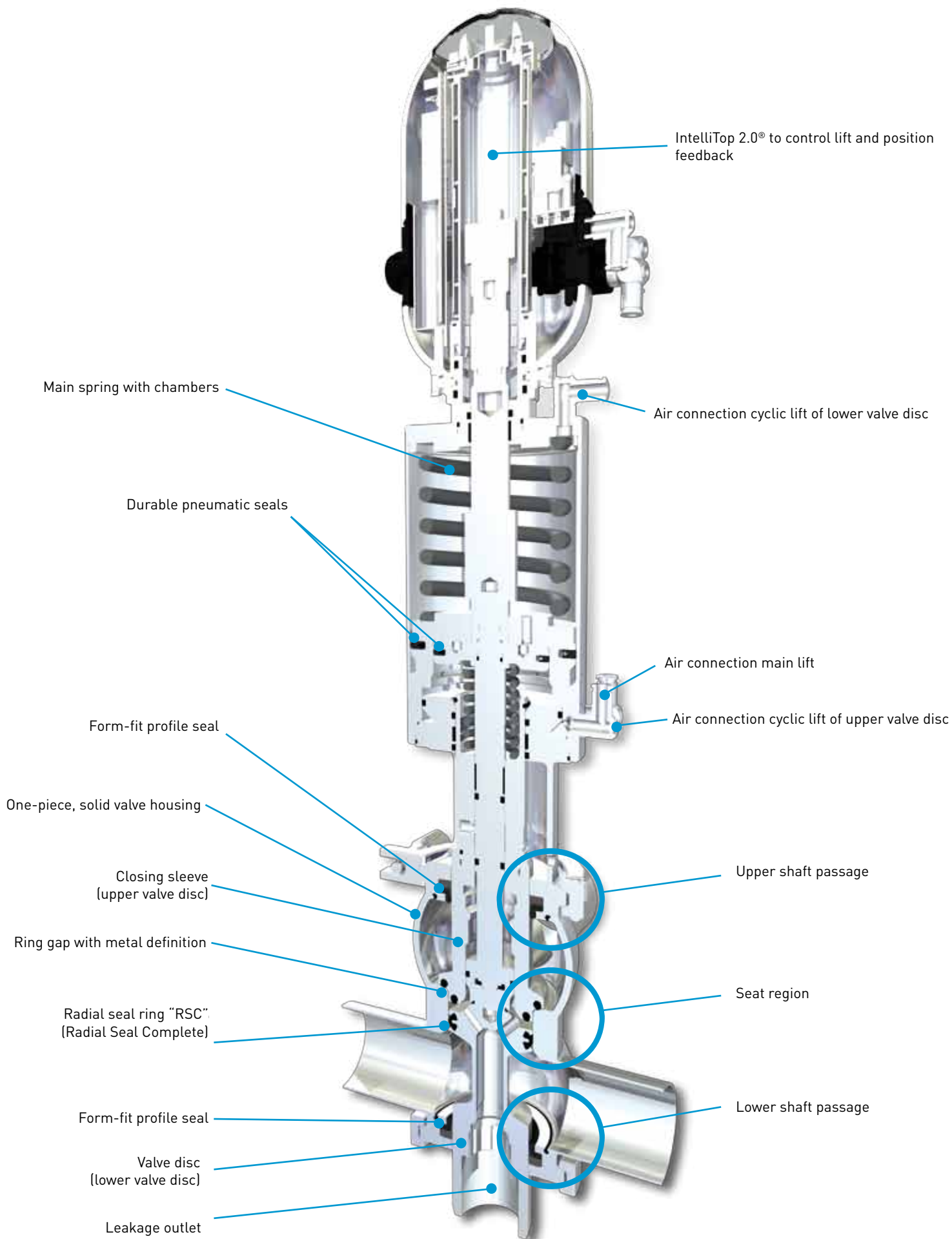

UPPER SHAFT PASSAGE



Support ring

Ensures better guidance and optimised friction behaviour

Profile seal

Minimised contact areas to ensure long life and improved wear and friction behaviour; special design prevents press-out (pressure pulses) or pull-out (sticky media).

O-ring

Seal between valve housing and housing holder

SEAT AREA (ON TYPE D 620)



Double O-ring seal

In the upper valve disc, the upper O-ring ensures a product seal in closed valve position, and lower O-ring ensures a leakage chamber seal in open valve position

RSC radial seal

Special shape ensures improved performance and doubling of swell compensation compared with conventional radial O-ring seals. Smaller contact area ensures longer life

LOWER SHAFT PASSAGE



Profile seal

Minimised contact areas to ensure long life and improved wear and friction behaviour; special design prevents press-out (pressure pulses) or pull-out (sticky media).

Support ring

Ensures improved guidance and optimum friction behaviour

O-ring

Seal between valve housing and housing cover

BASIC VALVE FUNCTIONS

BASIC VALVE POSITIONS

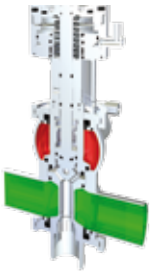

Valve closed



Valve open

Valve closed

- Media are separated, secure against mixing
- Any leaks escape to the environment without pressure

Valve open

- Lower valve disc lifts and closes the leakage chamber
- Product in the leakage chamber is discharged to the outside

VALVE CLEANING - CYCLIC FUNCTIONS

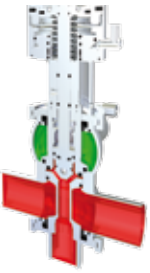

Cleaning via lower valve seat

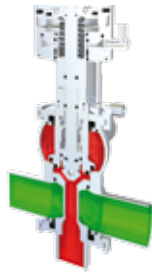

Cleaning via upper valve seat

Cleaning via lower valve seat

- Lower valve disc is raised while cleaning the lower rails (cyclic lift via predefined ring gap)
- Lower valve seat, disc seal, leakage chamber and leakage drain are cleaned

Cleaning via upper valve seat

- Upper valve disc is raised while cleaning the upper rails (cyclic lift via predefined ring gap)
- Upper valve seat, disc seal, leakage chamber and leakage drain are cleaned

EXTENDED VALVE FUNCTIONS

LEAKAGE CLEANING VIA EXTERNAL FLUSHING CONNECTION

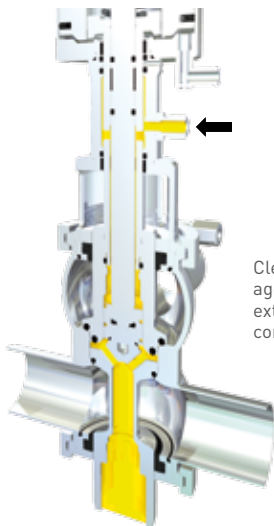

Cleaning of leakage chamber by external flushing connection

Cleaning of leakage chamber via external flushing connection

- Leakage chamber and leakage drain are cleaned via an external connection

STERILISATION / FLUSHING UPPER AND LOWER SHAFT AREA

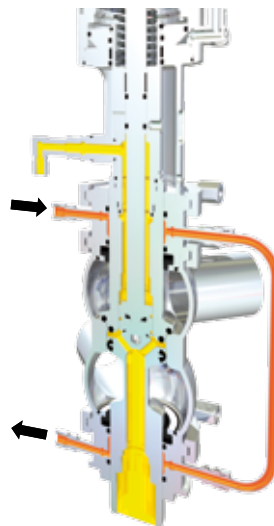

Valve sterilisation

Sterilisation or flushing via external connections

- Sterilisation or flushing of lower and upper shaft area

SHAFT FLUSHING OF LOWER VALVE DISC

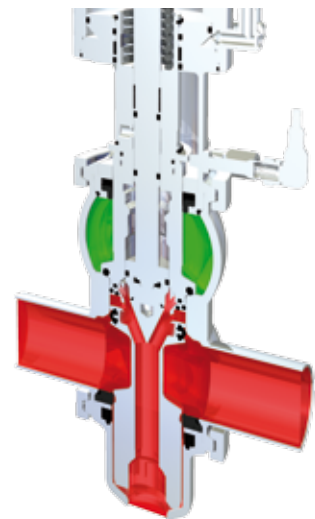

Flushing of lower shaft area (Scallop design)

- Flushing of shaft area during activation of cyclic lift of lower valve plate

DSV COMPLETE OPTIONS

Low leakage

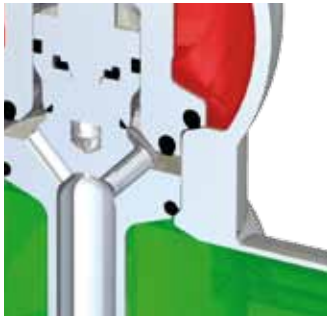

Closed

Lower valve disc with conical seal



Movement of lower disc

Lower rail **OPEN**
Leakage chamber open
->Flushing effect / Product loss

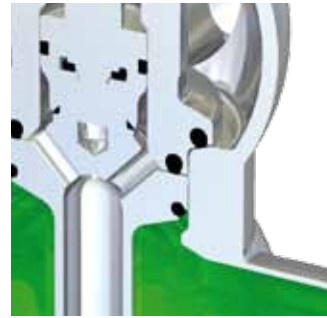

Movement of lower plate

Lower rail open
Leakage chamber closed

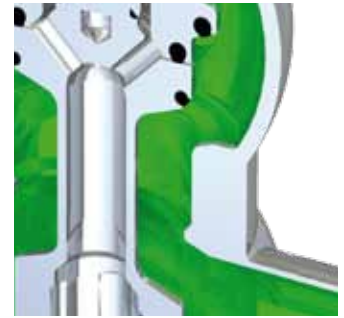

Open

Valve open
Leakage chamber closed

Leakage-free



Closed

Lower valve disc radial seal (RSC seal)



Movement of lower disc

Lower rail **CLOSED**
Leakage chamber open
-> No product loss



Movement of lower disc

Lower rail closed
Leakage chamber closed



Open

Valve open
Leakage chamber closed

DESIGNS	D600	D610	D620	D630	D620 S-sp	D620U	D640	D650	D365it PMO
Low product-loss switching (low leakage)	•	•							
Product-loss-free switching (leakage-free)			•	•	•	•	•	•	•
Cleaning of leakage chamber during cleaning by cyclic lift function	•		•		•	•	•	•	•
Cleaning of lower shaft during cleaning by cyclic lift function									•
Cleaning of leakage chamber via external flushing connection		•		•	•				
Sterile chambers (suitable for sterilising + flushing) in upper and lower shaft area					•				
Axial conical sealing O-rings in upper and lower valve discs	•	•							
Axial conical sealing O-ring in upper valve disc and radial sealing RSC seal in lower valve disc			•	•	•	• (2x)	•	•	•
One-piece housing	•	•	•	•	•		•	•	•

DESIGN D 600

- Low product loss switching (low leakage)
- Cycling of valve disc during cleaning allows cleaning of leakage chamber
- Lower valve disc conical seal (O-ring)

1. Valve closed
2. Valve open
3. Cyclic lift of lower valve disc
4. Cyclic lift of upper valve disc

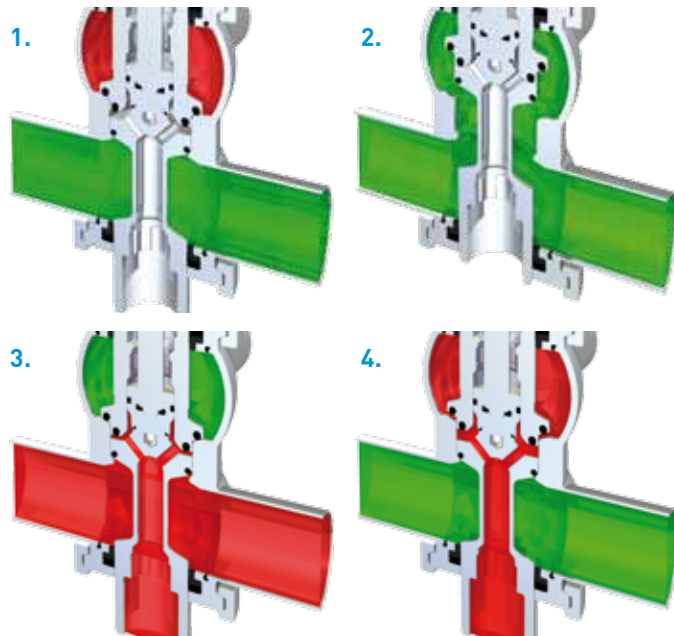

DESIGN D 610

- Low product loss switching (low leakage)
- No cyclic lift function
- Cleaning via external flushing connection
- Lower valve disc conical seal (O-ring)

1. Valve closed
2. Valve open
3. Cleaning via flushing connection

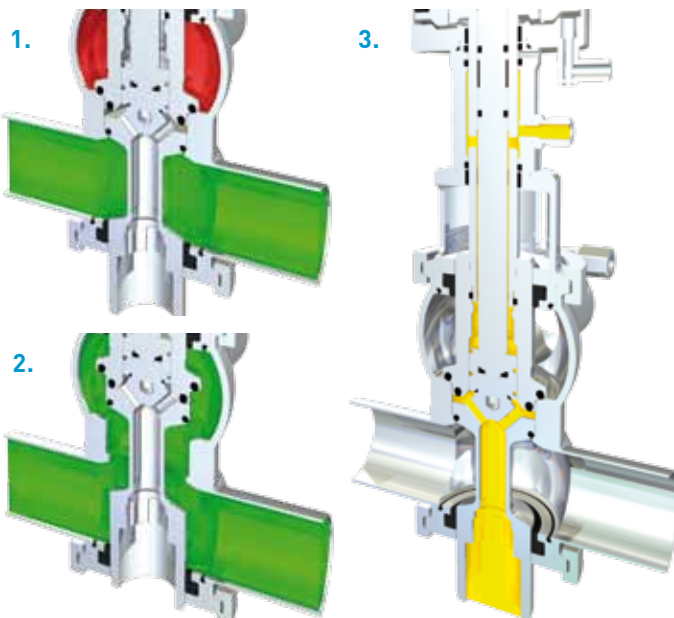

DESIGN D 620

- Product loss free switching (leakage free)
- Cycling of valve disc during cleaning allows cleaning of leakage chamber
- Lower valve disc radial seal RSC (Radial Seal Complete)

1. Valve closed
2. Valve open
3. Cycling lower seat
4. Cycling upper seat

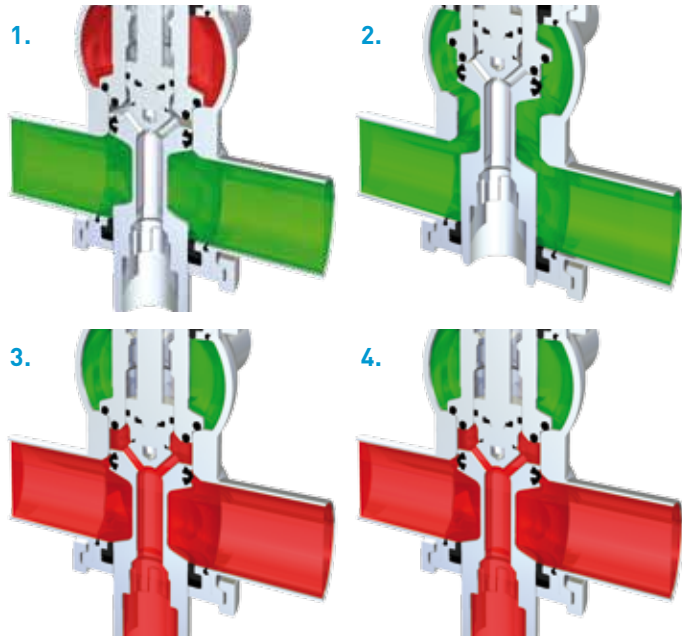

DESIGN D 630

- Product loss free switching (leakage free)
- No cyclic lift function
- Cleaning via external flushing connection
- Lower valve disc radial seal RSC (Radial Seal Complete)

1. Valve closed
2. Valve open
3. Cleaning via flushing connection

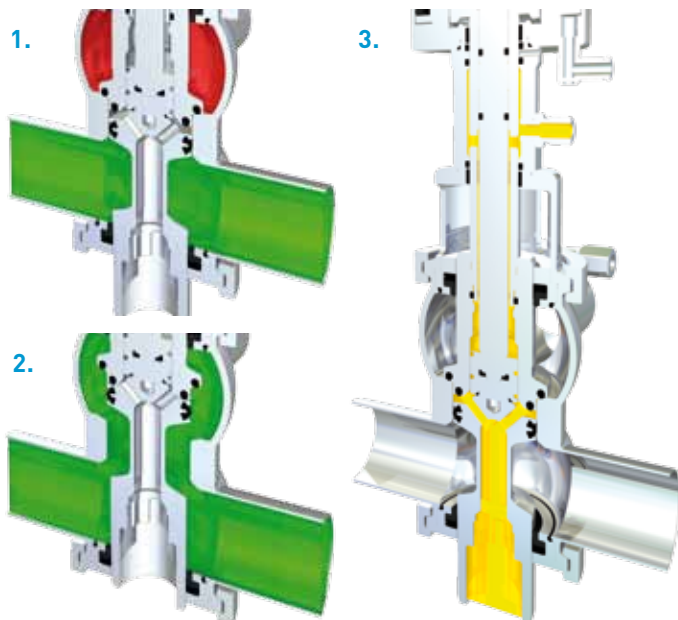

DESIGN D 620 S-Sp (suitable for sterilising – flushing)

- Product loss free switching (leakage free)
- Cycling of valve disc during cleaning allows cleaning of leakage chamber
- Flushing chamber for flushing/sterilisation of shaft areas
- Cleaning/sterilisation via external flushing connection (Sp)
- Lower valve disc radial seal RSC (Radial Seal Complete)

1. Valve closed
2. Valve open
3. Cyclic lift of lower valve disc
4. Cyclic lift of upper valve disc
5. Sterilisation/flushing

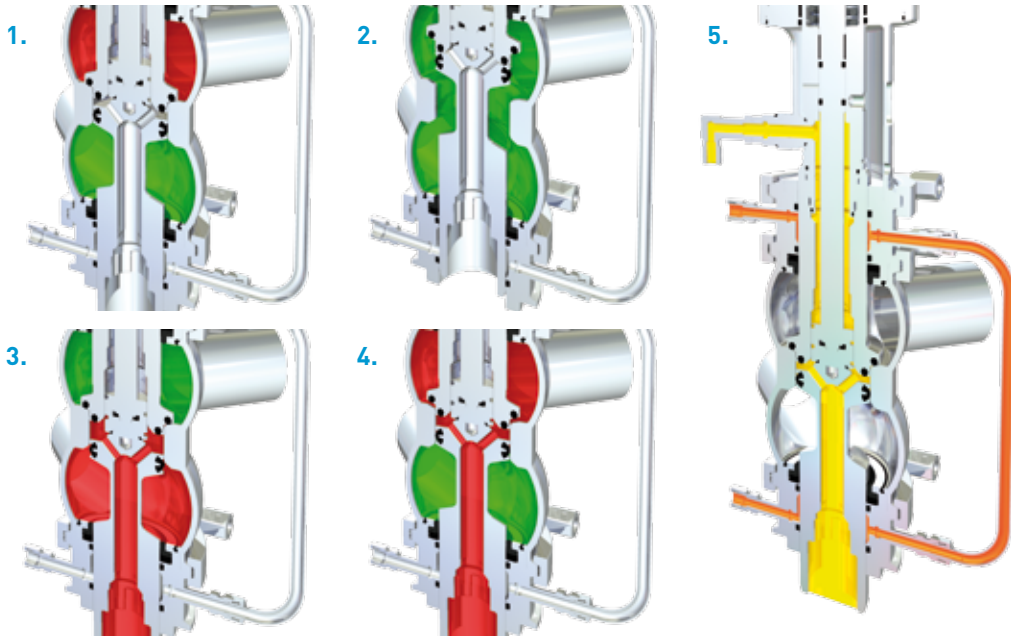

DESIGN D 620 U (change over valve)

- Product loss free switching (leakage-free)
- Cyclic lift functions for cleaning of leakage chamber
- Switchover function
- Lower valve disc radial seal RSC (Radial Seal Complete)

1. Valve closed
2. Valve open
3. Cyclic lift of lower valve disc
4. Cyclic lift of upper valve disc

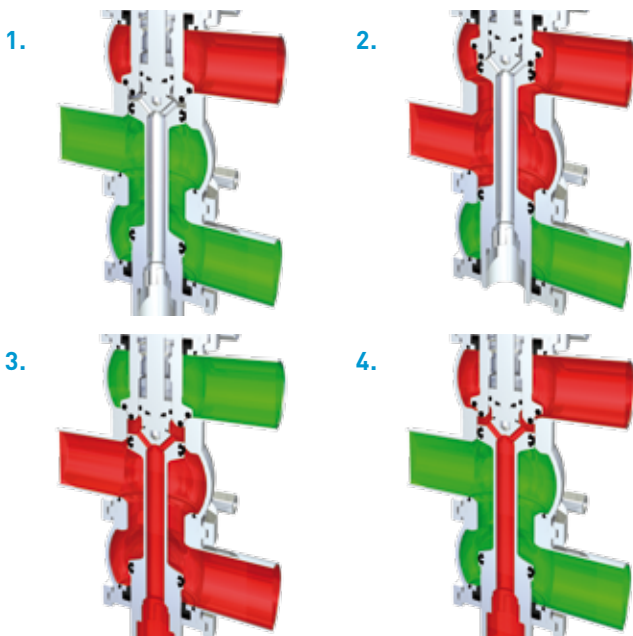

DESIGN D 640 (bottom seat valve / tank outlet valve)

- Product loss free switching (leakage free)
 - Cyclic lift functions for cleaning of leakage chamber
 - Lower valve disc radial seal RSC (Radial Seal Complete)
1. Valve closed
 2. Valve open
 3. Cyclic lift of lower valve disc
 4. Cyclic lift of upper valve disc

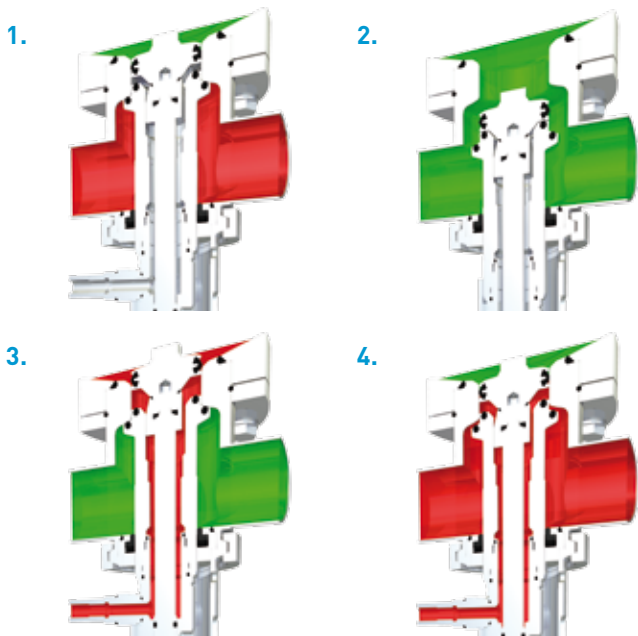

DESIGN D 650 (for ring pipes)

- Product loss free switching (leakage free)
 - Cyclic lift functions for cleaning of leakage chamber
 - Lower valve disc radial seal RSC (Radial Seal Complete)
1. Valve closed
 2. Valve open
 3. Cyclic lift of lower valve disc
 4. Cyclic lift of upper valve disc

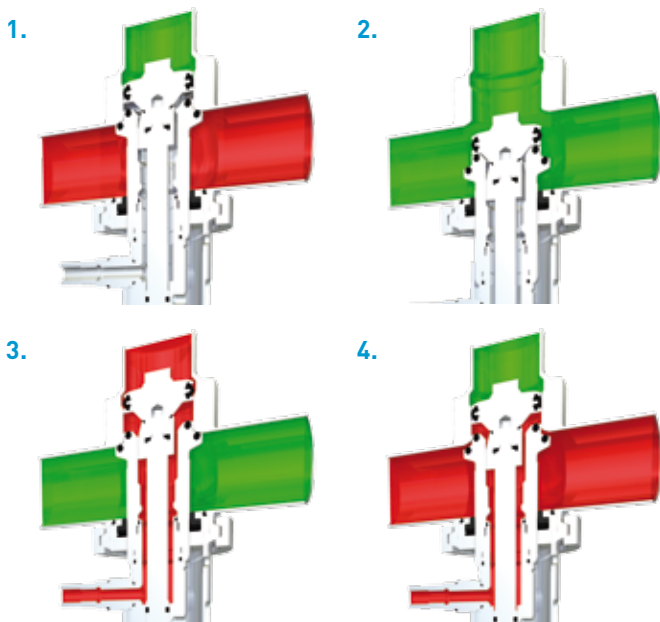

DESIGN D 365it PMO

- Product loss free switching (leakage free)
- Cyclic lift functions for cleaning of leakage chamber
- Lower valve disc radial seal RSC (Radial Seal Complete)
- Shaft flushing (for maximum security)
- Three-seat valve (deflector)
- Meets aligned requirements of PMO and 3A 85-02

1. Valve closed
2. Valve open
3. Cyclic lift of lower valve disc
4. Cyclic lift of upper valve disc

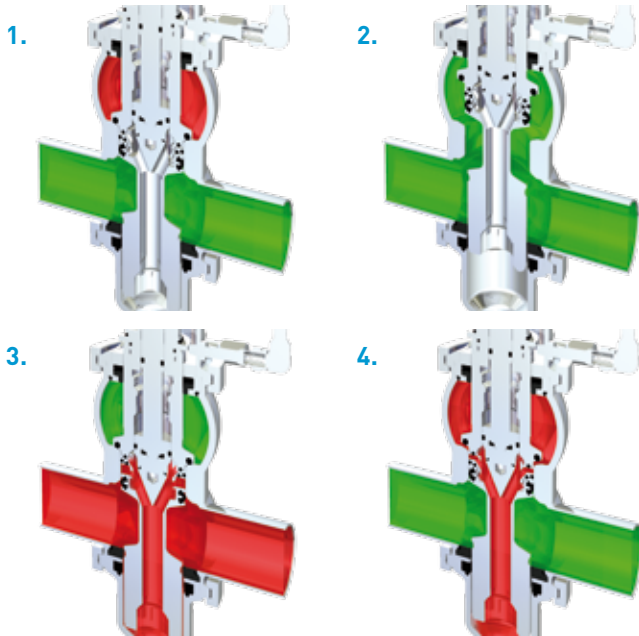

VARIANTS D 365it PMO

D 365it to Bottom Seat Valve / Tank Outlet Valve

Special design for direct integration into the tank. The design with no dead zones allows optimum tank cleaning.



D 365it Cheese curd design

The large open throat of the 365it Complete Cheese Curd Outlet PMO Mix Proof Valve provides gentle handling of the curd, and allows particles of up to approximately 1.5 inches to pass unobstructed through the valve.



GENERAL TECHNICAL DATA

MATERIAL

Area in contact with product
1.4404 (AISI 316L)

Area not in contact with product
1.4301 (AISI 304) / 1.4307 (AISI 304 L)

Optional
Higher quality materials

Seals*
EPDM / HNBR / FKM

*All seal qualities are FDA-compatible

PRESSURES

Control air pressure
Standard 6 bar (87 psi) – 8 bar (116 psi)

Operating pressure
Standard 10 bar (145 psi)*

Lower operating pressures apply to the following types:

D640 5 bar (72.5 psi)

D650 5 bar (72.5 psi)

*Depending on type and nominal width

SURFACES

Product wetted Ra ≤ 0,8 µm
Others Ra ≤ 1,6 µm

Optional
Higher-quality surfaces, e-polished

CONNECTIONS

Pipe dimensions in accordance with
- DIN 11850-2 (DIN 11866-A)
- ASTM A270 (DIN 11866-C) (ASME BPE-2009)
- DIN EN ISO 1127 (DIN 11866-B)

OPERATING TEMPERATURES

EPDM

Standard



Hot water
+95 °C (203 °F) continuous

Steam
+130 °C (266 °F) continuous
+150 °C (300 °F) brief sterilisation
(15-20 minutes)

Cold water
+1 to +2 °C (33.8 – 35.6°F) continuous

HNBR

optional



Hot water
+95 °C (203 °F) continuous

Steam
+121 °C (250 °F) continuous
+140 °C (284 °F) brief sterilisation (15-20
minutes)

Cold water
+1 to +2 °C (33.8 – 35.6°F) continuous

FKM

optional



Hot water
+80 °C (176 °F) continuous

Steam
+121 °C (250 °F) brief sterilisation (15-20
minutes)

Cold water
+1 to +2 °C (33.8 – 35.6°F) continuous

CONNECTION LAYOUT



D 621



D 622



D 623



D 624

CONNECTION MARKINGS

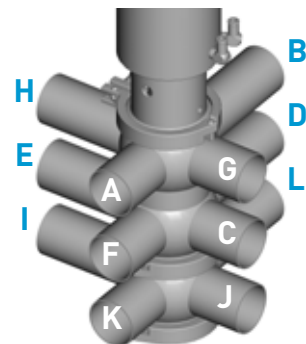

Different customer needs can be met thanks to the housing constructed of solid material. Discuss your needs with us at any time.

OPTIONAL ACCESSORIES

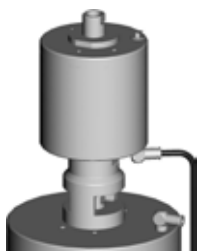

Air pressure amplifier / booster

- Supports main lift function
- Used for low control air pressure*

*Control air pressure depending on type & nominal width

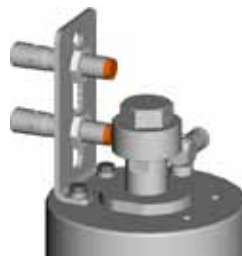

Position feedback OPEN/CLOSED

- Proximity initiator M12

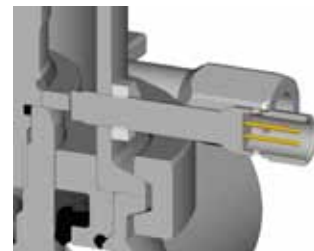

Position feedback upper valve disc

- Feedback CLOSED
- Proximity initiator M8

IDEAL FOR VALVE MANIFOLDS

DSV COMPLETE

PENTAIR SÜDMO VALVE NODES - OUR KNOW-HOW, YOUR SUCCESS

A successful process begins with the design and assembly of the valves into larger function units. As well as the pure functionality of the system, many other points must be taken into account:

- Selection of suitable components
- Correct installation position of all individual components
- Arrangement with no dead zones
- No sumps or domes
- Complete drainability
- Arrangement compatible with orbital welding
- Reduction in number of weld seams
- Compensation for heat expansion
- Adequate support and stabilisation of components
- Capture and discharge of leakage
- Simple maintenance work

PLANNING, DESIGN & PRODUCTION

3D drawing of a valve manifold

Before production comes planning. Using modern 3D systems, the valve manifold is planned in every detail and the result presented to the customer. Then production of the valve manifold can begin.

Building the frame

A stainless steel tube frame holds the valve manifold. Each frame is made individually to meet the customer's needs.

Mounting the valves

The individual parts of the valves for mounting come together on the workbench. The valve housing is sent directly to the plant construction.

Housing preparation

Before combining the valve housings into a manifold, the housings are equipped with flanges, elbows and other components using welding machines.

Orbital welding

The valve housing is welded using orbital welders. Together with accurate weld seam preparation, this ensures reproducible weld seams of the highest quality.

Preparation

All weld seams of the valve manifold are externally prepared mechanically. The valve manifold is then cleaned.

Fitting valve upper parts

Finally, the valve manifold is fitted with the valve upper parts, the air hoses suitable to the customer's needs, and the electric wiring for the process control heads is then subjected to a final test.

Finished valve manifolds

The finished valve manifolds can be installed in your plant directly after delivery and brought into operation.

CUSTOMER BENEFITS

- Cost-efficient complete package
- Decades of experience in design and production
- Compact construction
- Simple and rapid installation
- Perfect integration in process control (e.g. IntelliTop2.0 with 24VDC, AS interface, DeviceNet, or 110VAC)
- Countless possible variations in consultation with our experts
- Simple access for maintenance (e.g. with access platforms or steps)
- Excellent WIG weld seam qualities to DIN EN 287
- Valve node production observing Pressure Vessel Directive 97/23/EC

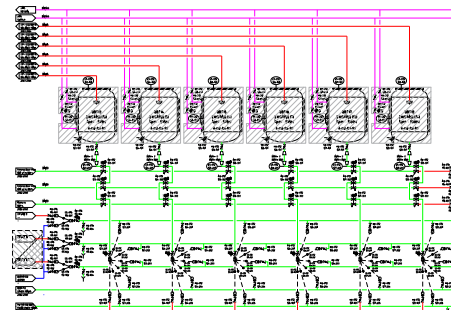

INTELLIGENT CONTROL TECHNOLOGY

INTELLITOP® 2.0



The innovative control unit offers the customer countless possibilities for automation of process systems, and hence considerable potential for increasing efficiency.

The IntelliTop 2.0 was awarded the IF Product Design Award 2010 for its perfect combination of function and aesthetics.

The IntelliTop 2.0 control unit from Pentair Südmo combines control and monitoring of process valves in one unit. The decentral arrangement of the control heads on the process valves allows a reduction in hose and cable lengths and leads to a clear system structure.

The heart of the IntelliTop 2.0 is the travel measurement system to detect up to three switch positions of the process valve. Great emphasis has been placed on simple programming by means of three Teach-In keys. This guarantees rapid and process-reliable commissioning. At the same time, the closed travel measurement system serves as a protective tube which prevents risk of injury when the control head is open, and protects the internal technology on installation of the head.

BENEFITS

Communication

24 V DC
AS interface
DeviceNet
110 V AC

Travel Measurement System

Lift range 85 mm
Feedback 3 positions, adjustable, connection for external signal

Magnetic valves

Number 0-3 pcs
Flow 200 l/min
Choke function Intake and extraction air separate

Electrical connections

24 VDC Cable passage
AS interface Cable with 4-pin M12x1 plug
DeviceNet Cable with 5-pin M12x1 plug
110 V AC Cable passage

Pneumatic connections

Push-fit hose connection Ø 6 mm (optional 5/16")
Push-fit hose connection Ø 8 mm (1/4")

Other data

LED status display green, yellow, red
Protection classes IP65 and IP 67 combined IP 69K
Ex-zone Zone 2/22

TECHNICAL DATA BENEFITS

- Process-reliable system monitoring, simple, intuitive and rapid implementation
- Process valve switch times can be set using integral supply and extraction air chokes
- All-round LED display for visual status monitoring (colour allocation can be configured)
- Simplified valve maintenance thanks to maintenance function which can be activated externally
- Plant-specific adaptations via integrated microcontroller
- Integrated microcontroller supplies additional information
- Short air hose and cable routes, clear structure of process plant
- Simple, rapid fault analysis and repair, so reduction in plant downtimes
- Compact construction and optimum compatibility with Pentair Südmo process valves
- Scanning of all valve positions possible in double-seat valve





SÜDMO COMPONENTS GMBH

INDUSTRIESTRASSE 7, 73469 RIESBÜRG, GERMANY WWW.SUEDMO.DE

All Pentair trademarks and logos are owned by Pentair, Inc. All other brand or product names are trademarks or registered marks of their respective owners. Because we are continuously improving our products and services, Pentair reserves the right to change specifications without prior notice.

Pentair is an equal opportunity employer.

DSV Brochure E-1/12 © 2012 Pentair, Inc. All Rights Reserved.